

# EMERGENCY LIGHTING AND ORIENTATION SYSTEMS

ARSEL 

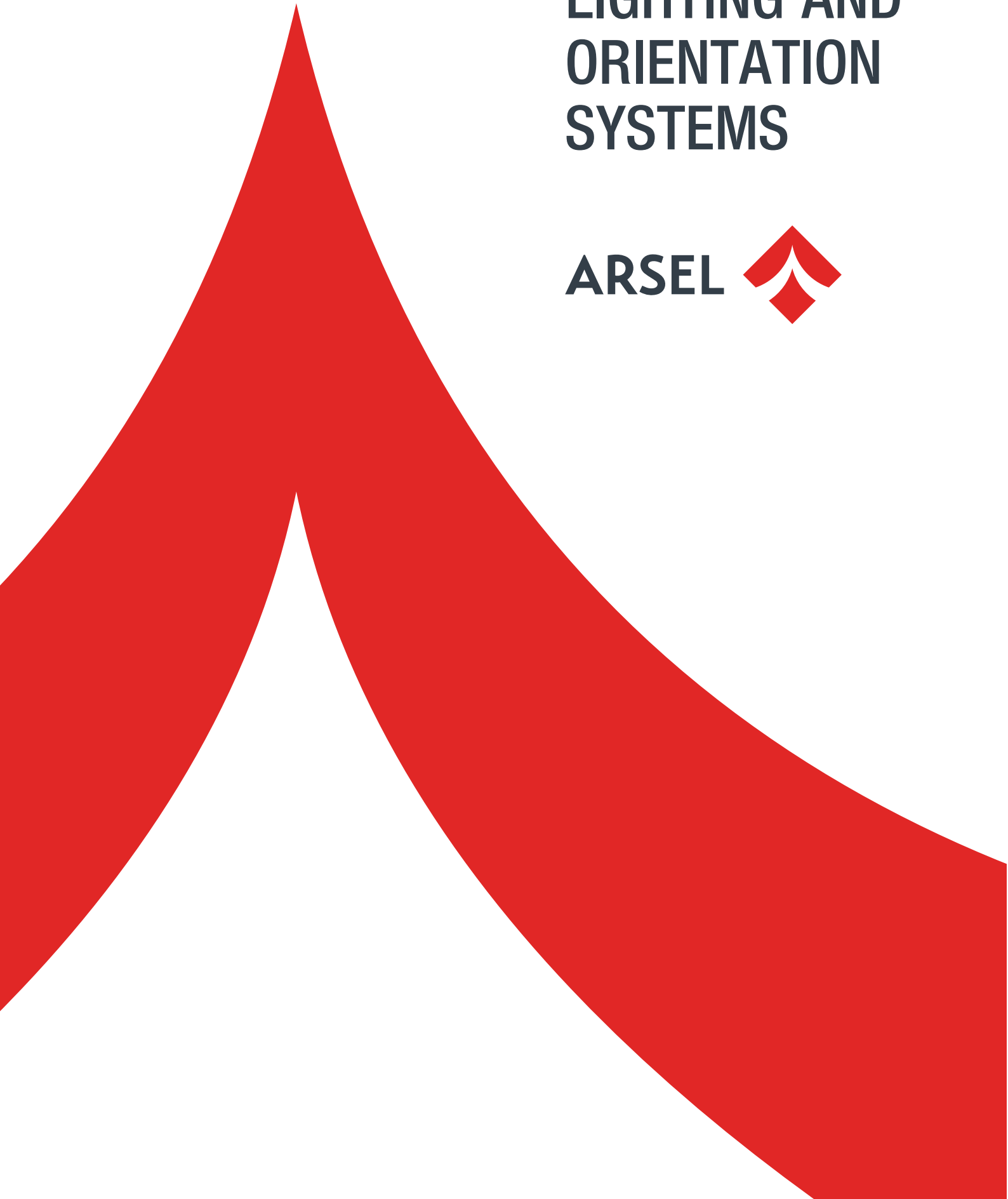



## AK-2400 EMERGENCY BATTERY PACK FOR LED'S

- Emergency backup units for LED lamps
- It can be used with an armature mounted inside or with an external box.
- Supplied with Ni-Cd Battery.

AK-2400 model emergency backup modules;

- It is connected to the supply input of the LED drivers, which can operate with AC voltage below 25 watts.
- Maximum 5 may switch the DC LED current.
- 12 volt ni-cd battery, are plug-in type terminals.
- Backup output 220 volts 50 Hz 25 w maximum
- It should be installed inside the armature or in the external box.
- Provides power failure backup for LED lamps.
- Battery charging indicator.
- The lamp's 2 connections are switched at once.
- With fully insulated supply circuit and the lamp contacts, there is no damage due to the different phase connections.
- Continuous charging method keeps the battery pack full and ready.
- Appropriate kit should be selected according to the lamp.
- Plug-in type latching type terminals are used for easy installation.
- The mains supply voltage is standard 220 volts AC 50 Hz.
- Charging time for first use is 24 hours.
- It can withstand fluctuations up to 285 volts at mains voltage.
- Switches to emergency lighting mode under 150 volts, charging over 185 volts
- It is manufactured according to TS 8710 EN60598-2-22 standard in the framework of ISO 9001-2000 quality management system.

### USAGE AREAS

- LED lighting fixtures
- Emergency lighting and guidance fittings
- Waterproof type LED lighting fixtures
- Special design led lighting fixtures
- Recessed type luminaires

### BODY STRUCTURE

- Body - Electrostatic powder coated aluminum case. ABS plastic covers.

### BATTERY

- BATTERY - Nickel-cadmium in all models

### OPTIONS

- Model choices according to lamp type and power
- 1-2 hour emergency backup times



## EMERGENCY BACKUP UNITS FOR LED LAMPS

MODEL CODE	LIGHTING STYLE	USAGE TYPE	LAMP	DURATION	BATTERY	WEIGHT (Batt inc.)	IP CLASS	ISOLATION CLASS	OPERATION TEMP	POWER CONSUMPTION	OPERATING VOLTAGE
AK-312-1	Non-Maintained	Internal	12 volt led lamp	Emergency 60 m.	3 cell AA size	0,28kg	30	I	-16/+40°	1,5 watt	220-240
AK-312-2	Non-Maintained	Internal	12 volt led lamp	Emergency 120 m.	3 cell SC size	0,35kg	30	I	-16/+40°	1,5 watt	220-240
AK-312-3	Non-Maintained	Internal	12 volt led lamp	Emergency 180 m.	3 cell SC size	0,38kg	30	I	-16/+40°	1,5 watt	220-240
AK-4600-1	Non-Maintained	Internal	3,5-70 volt led lamp	Emergency 60 m.	4 cell AA size	0,27kg	30	I	-16/+40°	1,5 watt	220-240
AK-4600-3	Non-Maintained	Internal	3,5-70 volt led lamp	Emergency 180 m.	4 cell SC size	0,37kg	30	I	-16/+40°	1,5 watt	220-240
AK-7200-1	Non-Maintained	Internal	3,5-200 volt led lamp	Emergency 60 m.	6 cell AA size	0,33kg	30	I	-16/+40°	1,5 watt	220-240
AK-7200-2	Non-Maintained	Internal	3,5-200 volt led lamp	Emergency 120 m.	6 cell SC size	0,5kg	30	I	-16/+40°	1,5 watt	220-240
AK-7200-3	Non-Maintained	Internal	3,5-200 volt led lamp	Emergency 180 m.	6 cell SC size	0,5kg	30	I	-16/+40°	1,5 watt	220-240
AK-609W-1	Non-Maintained	Internal	110-220 volt AC led lamp	Emergency 60 m.	5 cell SC size	0,45kg	30	I	-16/+40°	3,5 watt	220-240
AK-609W-2	Non-Maintained	Internal	110-220 volt AC led lamp	Emergency 120 m.	5 cell D size	0,75kg	30	I	-16/+40°	3,5 watt	220-240
AK-4600S-1	Non-Maintained	Internal	3,5-70 volt led lamp	Emergency 60 m.	6 cell AA size	0,27kg	30	I	-16/+40°	1,5 watt	220-240
AK-4600S-3	Non-Maintained	Internal	3,5-70 volt led lamp	Emergency 180 m.	6 cell AA size	0,30kg	30	I	-16/+40°	1,5 watt	220-240
AK-4600S-EKO	Non-Maintained	Internal	12-65 volt led lamp	Emergency 180 m.	6 cell AA size	0,27kg	30	I	-16/+40°	1,5 watt	220-240
AK-2400	Non-Maintained	Internal	220 volt <25w lamp	-	-	0,5kg	30	I	-16/+40°	1,5 watt	220-240

## DIMENSIONS

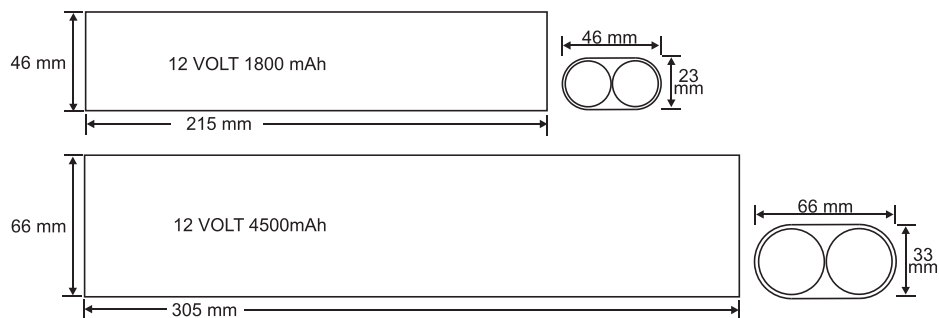
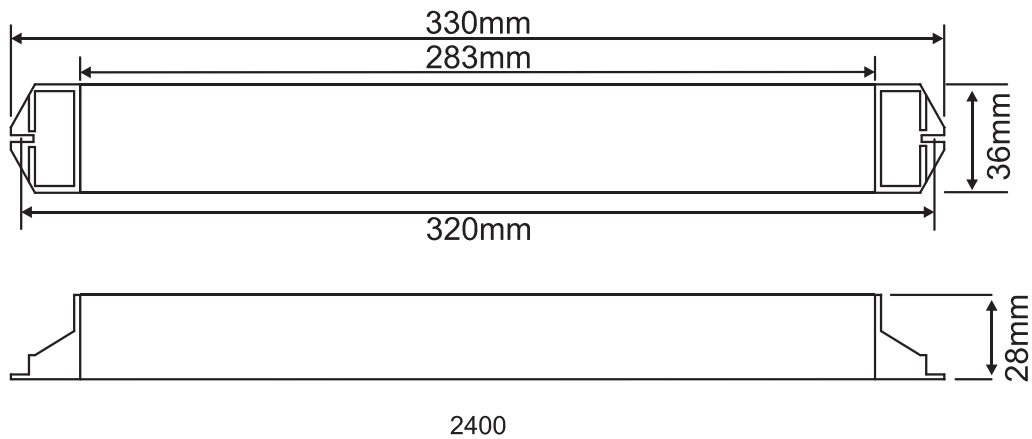

AK-2400 BATTERIES